



4JH4-HTE

Configuration	In-line, 4-stroke, vertical, water-cooled diesel engine	
Max. output at crankshaft*	80.9 kW@3200 rpm	[110 mhp@3200 rpm]
No. of cylinders	4 cylinder	
Displacement	1.995 L	[121.7 cu in]
Bore x stroke	84 mm x 90 mm	[3.31 in x 3.54 in]
Aspiration	Turbocharged & intercooled	
Combustion system	Direct injection, Bosch distributor type VE pump	
Starting system	Electric starting 12V - 1.4 kW	
Engine management	Mechanical	
Cooling system	Fresh water cooling by centrifugal fresh water pump Seawater cooling by rubber impeller seawater pump	
Alternator	12V - 125A	
Lubrication system	Enclosed, forced lubricating system	
Engine lube oil specifications	API class: CD or higher, SAE grade: 10W-30 or 15W-40	
Direction of rotation at crankshaft	Counterclockwise (CCW) viewed from stern	
Dry weight without gear	217 kg	[478 lbs]
Engine dimensions† L x W x H	933 x 661 x 659 mm	
Emission compliance	EU: RCD 2, BSO II, EMC	US: EPA Tier 2
Flywheel housing size	SAE #4	
Controls	Mechanical	

NOTE:Fuel condition: Density at 15°C = 0.84 g/cm³; 1 kW = 1.3596 mhp = 1.3410 HP

Technical data is according to ISO 8665: 2006/3046-1

* Fuel temperature 40°C at the inlet of the fuel injection pump [ISO 8665]

†Length includes KM4A2 marine gear (Dimensions may vary with other gears/elbow)

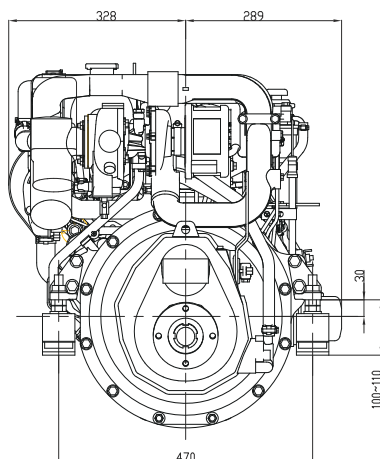
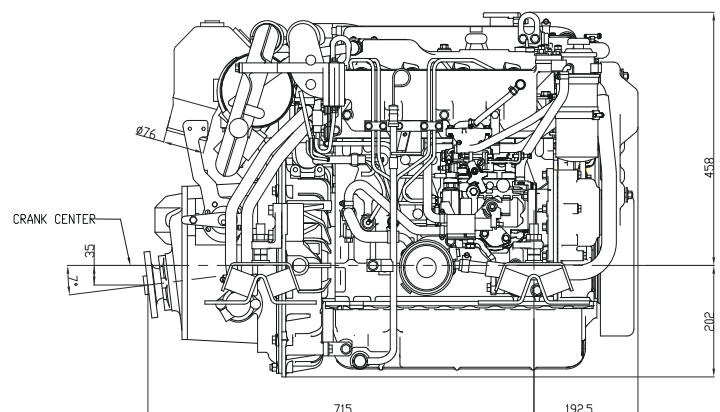
DIMENSIONS**Rear view****Right side view**4JH4-HTE with KM4A2 marine gear
(Not to be used for engine installation)



PERFORMANCE CURVES

4JH4-HTE Torque curve

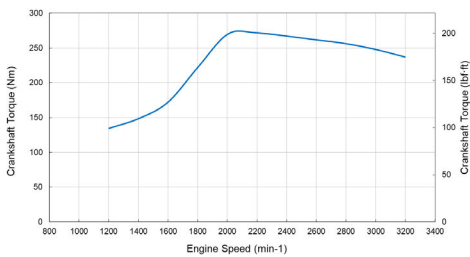

4JH4-HTE Output Power curve

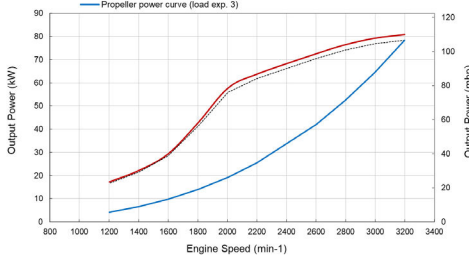

4JH4-HTE Fuel consumption (propload exp 3.0)

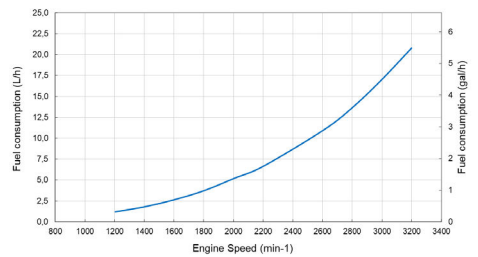

MARINE GEAR*

Model	ZF30M [parallel]	KM4A2 [down angle: 7°]	KMH4A [down angle: 8°]	ZF25A [down angle: 8°]
Clutch type	Mechanical multi-disc	Mechanical cone	Hydraulic multi-disc	Hydraulic multi-disc
Dry weight	28 kg [61 lbs]	28.5 kg [63 lbs]	30 kg [66 lbs]	30 kg [66 lbs]
Reduction ratio [fwd/asn]	2.15/2.64 2.70/2.64	1.47/1.47 2.14/2.14 2.63/2.63	2.04/2.04 2.45/2.45	1.93/1.93 2.48/2.48
Direction of rotation [viewed from stern]	Clockwise	Clockwise & counterclockwise	Clockwise & Counterclockwise	Clockwise & counter clockwise
Lubrication system	Splash lubrication	Splash lubrication	Trochoid pump	Trochoid pump
Lube oil specifications	ATF	API class: CD or higher, SAE grade: #20 or #30		ATF
Max. lube oil capacity	1.1 L	2.0 L	2.0 L	1.8 L
Dry weight - engine & gear	245 kg [540 lbs]	245.5 kg [541 lbs]	247 kg [545 lbs]	247 kg [545 lbs]

* Other marine gearboxes and configurations available upon request. Contact your local supplier for more information.

INSTRUMENT PANELS

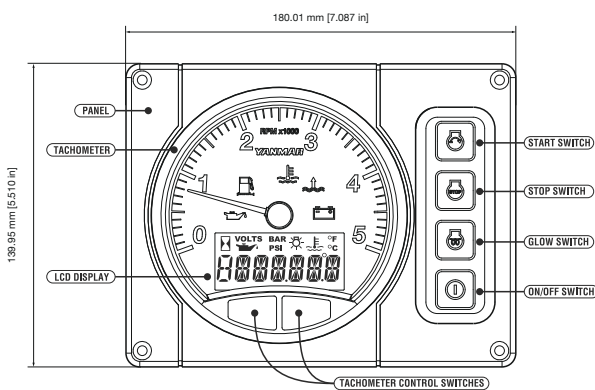

B20 panel

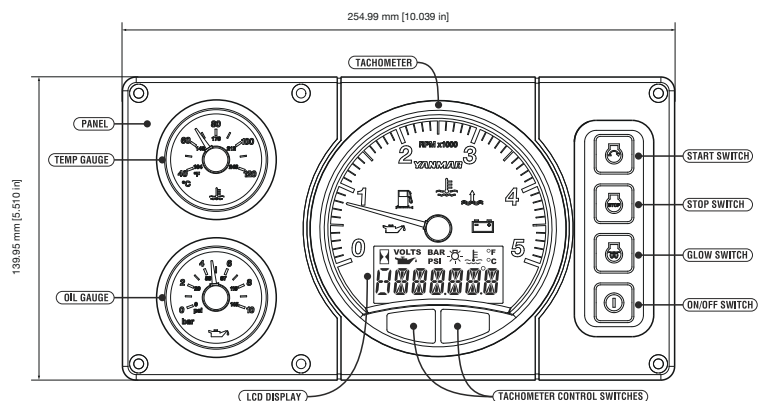

C30 panel

ACCESSORIES

Standard engine package

- Exhaust mixing elbow [L-type]
- Alternator 12V - 125A
- B20 panel
- Flexible mounts
- Expansion tank for fresh water cooling system
- Electric stop solenoid
- Belt safety cover

Optional accessories

- High-riser mixing elbow [instead of L-elbow]
- Secondary alternator 12V - 130A or 24V - 75A including smart regulator
- C30 panel
- Extension wire harness [4m, 6m 10m]
- Dual harness [for 2nd station]
- TFX Sidemount control head

- SOLAS including Certificate [factory fit only]
- Hot water kit with cocks
- Extension saildrive leg [75 mm]
- Propeller cone nut kit SD60
- Air heater [glow]
- Trolling valve [only for KMH4A]

NOTE: All data subject to change without notice. Text and illustrations are not binding.