



4JH5E

Configuration	In-line, 4-stroke, vertical, water-cooled diesel engine	
Max. output at crankshaft*	39.6 kW@3000 rpm	[53.8 mhp@3000 rpm]
No. of cylinders	4 cylinder	
Displacement	2.190 L	[134 cu in]
Bore x stroke	88 mm x 90 mm	[3.46 in x 3.54 in]
Aspiration	Natural	
Combustion system	Direct injection, mono plunger pump	
Starting system	Electric starting 12V - 1.4 kW	
Engine management	Mechanical	
Cooling system	Fresh water cooling by centrifugal fresh water pump Seawater cooling by rubber impeller seawater pump	
Alternator	12V - 125A	
Lubrication system	Enclosed, forced lubricating system	
Engine lube oil specifications	API class: CD or higher, SAE grade: 10W-30 or 15W-40	
Direction of rotation at crankshaft	Counterclockwise (CCW) viewed from stern	
Dry weight without gear	201 kg	[443 lbs]
Engine dimensions† L x W x H	871 x 560 x 623 mm	
Emission compliance	EU: RCD 2, BSO II, EMC	US: EPA Tier 2
Flywheel housing size	SAE #5	
Controls	Mechanical	

NOTE:Fuel condition: Density at 15°C = 0.84 g/cm³; 1 kW = 1.3596 mhp = 1.3410 HP

Technical data is according to (ISO 8665) / (ISO 3046)

* Fuel temperature 40°C at the inlet of the fuel injection pump (ISO 8665)

†Length includes KM35A marine gear (Dimensions may vary with other gears/elbow)

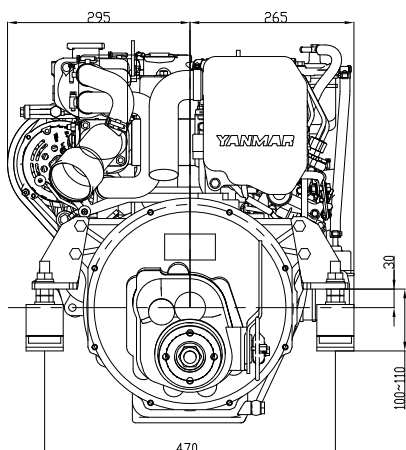
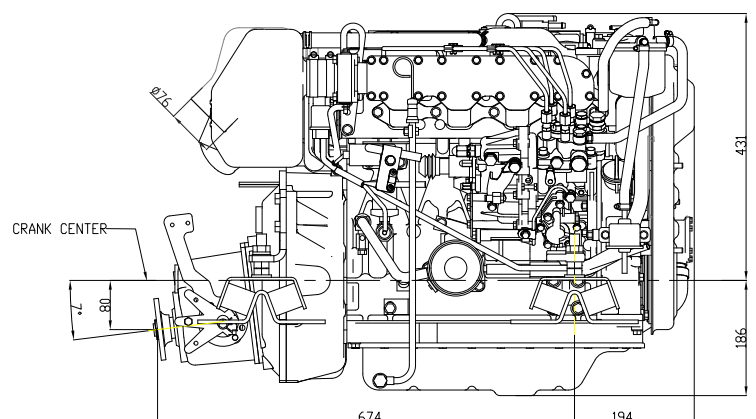
DIMENSIONS**Rear view****Right side view**4JH5E with KM35A2 marine gear
(Not to be used for engine installation)



PERFORMANCE CURVES

4JH5E Torque curve

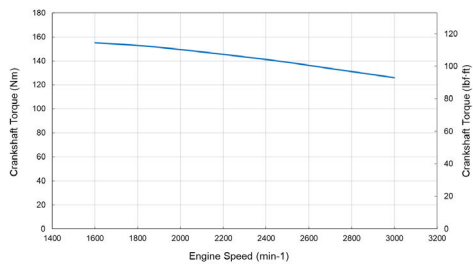

4JH5E Torque curve

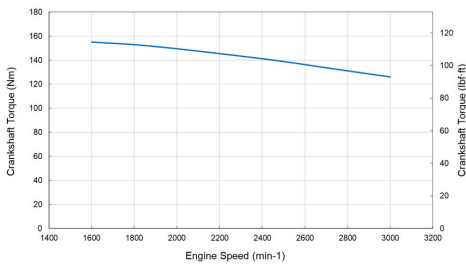

4JH5E Fuel consumption (propload exp 3.0)

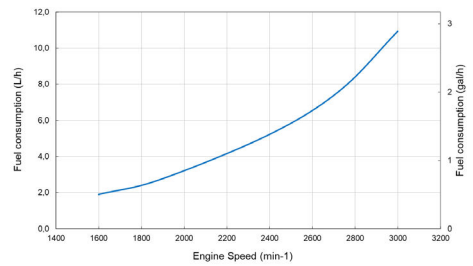

MARINE GEAR / DRIVE*

Model	KM35P	KM35A2 [down angle: 7°]	KM4A1-5 [down angle: 7°]	ZF30M [paralle]	Saildrive [SD60]
Clutch type	Mechanical cone clutch	Mechanical cone clutch	Mechanical cone clutch	Mechanical multi-disc	Mechanical multi-disc
Dry weight	12 kg [26 lbs]	13 kg [29 lbs]	30 kg [66 lbs]	28 kg [61 lbs]	44 kg [97 lbs]
Reduction ratio [fwd/asn]	2.36/3.16 2.61/3.16	2.33/3.04 2.64/3.04	1.47/1.47 2.14/2.14 2.63/2.63	2.15/2.64 2.70/2.64	2.23/2.23 2.49/2.49
Direction of rotation [viewed from stern]	Clockwise	Clockwise	Clockwise & counterclockwise	Clockwise	Clockwise & counter clockwise
Lubrication system	Splash lubrication	Splash lubrication	Splash lubrication	Splash lubrication	Splash lubrication
Lube oil specifications	API class: CD or higher, SAE grade: #20 or #30			ATF	API class: CD or higher, SAE grade: 15W-40
Max. lube oil capacity (L)	0.5 L	0.65 L	2.3 L	1.8 L	3.1 L
Dry weight - engine & gear	213 kg [469.5 lbs]	214 kg [471.7 lbs]	231 kg [509 lbs]	229 kg [505 lbs]	245 kg [540 lbs]

* Other marine gearboxes and configurations available upon request. Contact your local supplier for more information.

INSTRUMENT PANELS

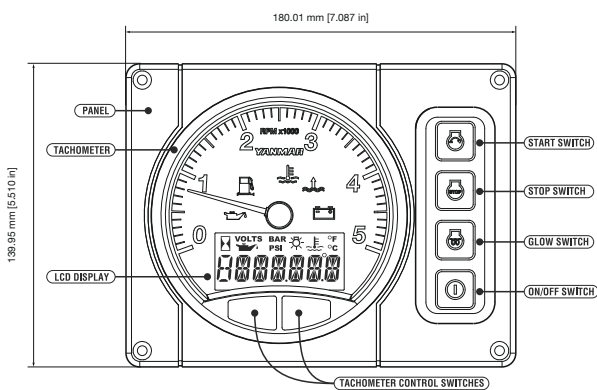

B20 panel

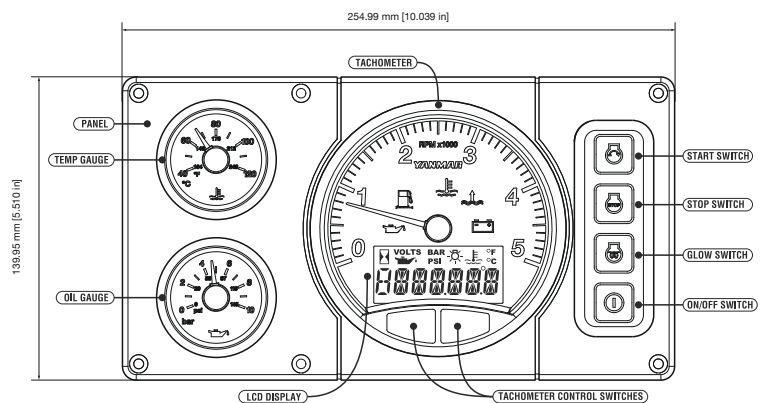

C30 panel

ACCESSORIES

Standard engine package

- Exhaust mixing elbow [L-type]
- Alternator 12V - 125A
- B20 panel
- Flexible mounts
- Expansion tank for fresh water cooling system
- Electric stop solenoid
- Belt safety cover

Optional accessories

- High-riser mixing elbow [instead of L-elbow]
- Secondary alternator 12V - 130A or 24V - 75A including smart regulator
- C30 panel
- Extension wire harness [4m, 6m 10m]
- Dual harness [for 2nd station]
- TFX Sidemount control head

- Hot water kit with cocks
- Extension saildrive leg [75 mm]
- Propeller cone nut kit SD60
- Air heater [glow]
- On-board spare parts kit

NOTE: All data subject to change without notice. Text and illustrations are not binding.