



# 4JH3-DTE

Configuration	In-line, 4-stroke, vertical, water-cooled diesel engine	
Max. output at crankshaft	* 89.1 kW@3800 rpm	[121 mhp@3800 rpm]
	** 91.9 kW@3800 rpm	[125 mhp@3800 rpm]
No. of cylinders	4 cylinder	
Displacement	1.995 L	[121.7 cu in]
Bore x stroke	84 mm x 90 mm	[3.31 in x 3.54 in]
Aspiration	Turbocharged & intercooled	
Combustion system	Direct injection, Bosch distributor type VE pump	
Starting system	Electric starting 12V - 1.4 kW	
Engine management	Mechanical	
Cooling system	Fresh water cooling by centrifugal fresh water pump	
	Seawater cooling by rubber impeller seawater pump	
Alternator	12V - 125A	
Lubrication system	Enclosed, forced lubricating system	
Engine lube oil specifications	API class: CD or higher, SAE grade: 10W-30 or 15W-40	
Direction of rotation at crankshaft	Counterclockwise (CCW) viewed from stern	
Dry weight without gear	229 kg	[505 lbs]
Engine dimensions† L x W x H	1001.3 x 581 x 661 mm	
Emission compliance	EU: RCD 2, BSO II, EMC	US: EPA Tier 2
Flywheel housing size	SAE #4	
Controls	Mechanical	

NOTE: Fuel condition: Density at 15°C = 0.84 g/cm<sup>3</sup>; 1 kW = 1.3596 mhp = 1.3410 HP

\* Fuel temperature 40°C at the inlet of the fuel injection pump [ISO 8665: 2006]

\*\* Fuel temperature 25°C at the inlet of the fuel injection pump [ISO 3046-1]

†Length includes KM4A2 marine gear (Dimensions may vary with other gears/elbow)

## DIMENSIONS

Rear view

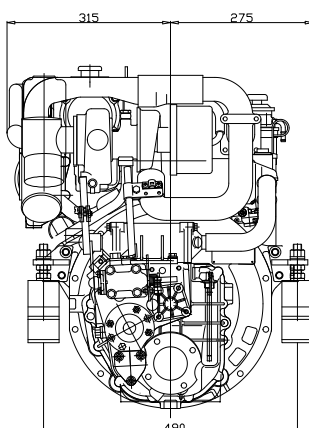

Right side view

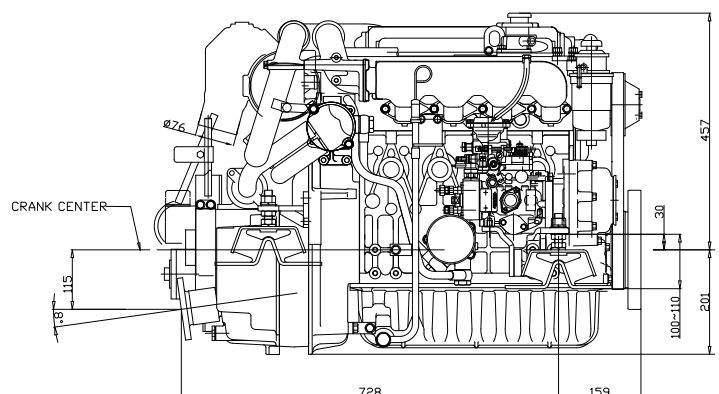

4JH3-DTE with KM4A2 marine gear  
(Not to be used for engine installation)



PERFORMANCE CURVES

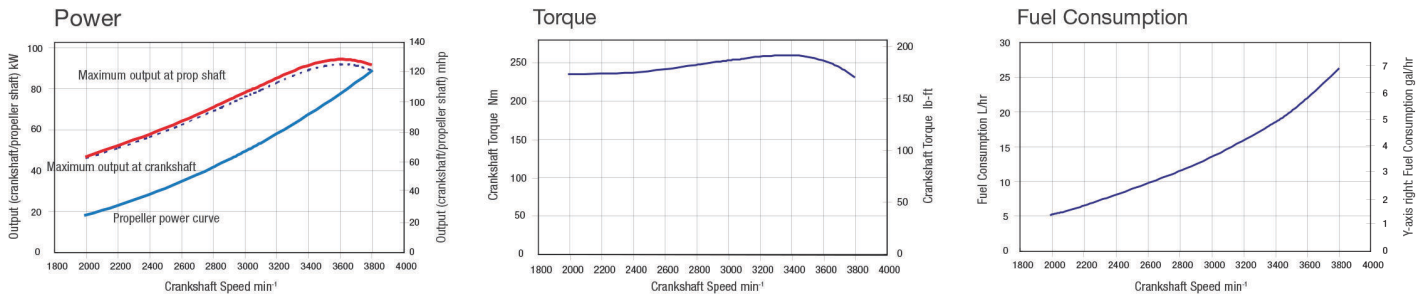

MARINE GEAR\*

Model	KMH4A [down angle: 8°]		ZF25A [down angle: 8°]		
Clutch type	Hydraulic multi-disc		Hydraulic multi-disc		
Dry weight	30 kg [66 lbs]		30 kg [66 lbs]		
Reduction ratio [fwd/asn]	2.04/2.04	2.45/2.45	2.23/2.23	2.49/2.49	2.71/2.71
Direction of rotation [viewed from stern]	Clockwise & counterclockwise		Clockwise & counterclockwise		
Lubrication system	Trochoid pump		Trochoid pump		
Lube oil specifications	API class: CD or higher, SAE grade: #20 or #30		ATF		
Max. lube oil capacity	2.0 L		1.8 L		
Dry weight - engine & gear	259 kg [571 lbs]		259 kg [571 lbs]		

\* Other marine gearboxes and configurations available upon request. Contact your local supplier for more information.

INSTRUMENT PANELS

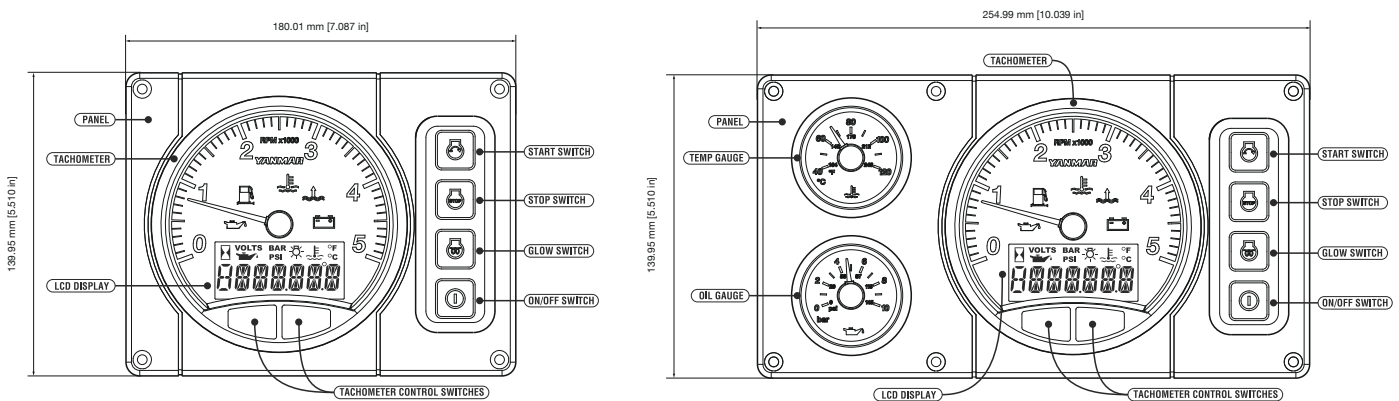

B20 panel

C30 panel

ACCESSORIES

**Standard engine package**

- Exhaust mixing elbow [L-type]
- Alternator 12V - 125A
- B20 panel
- Flexible mounts
- Expansion tank for fresh water cooling system
- Electric stop solenoid
- Belt safety cover

**Optional accessories**

- High-riser mixing elbow [instead of L-elbow]
- C30 panel
- Extension wire harness [4m, 6m 10m]
- Dual harness [for 2nd station]
- TFX Sidemount control head
- Air heater [glow]
- Trolling valve [only for KMH4A]
- On-board spare parts kit

NOTE: All data subject to change without notice. Text and illustrations are not binding.